

Industrial Explosion Proof Balance Scales

MODEL : SPVL-TD-70W



제품 규격 [UNIT : mm]

Product Specification

Pendant Type

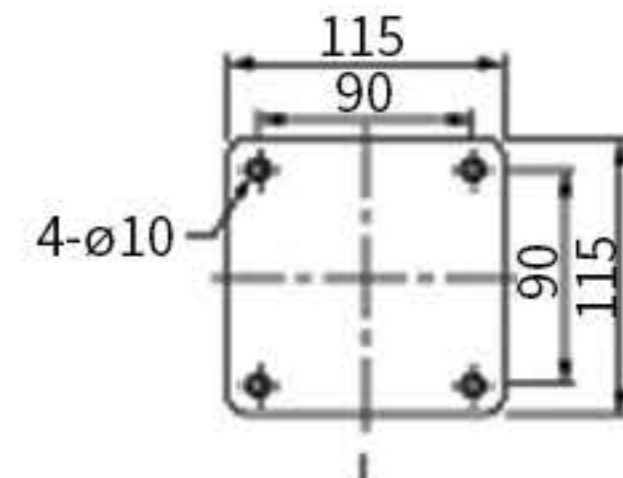
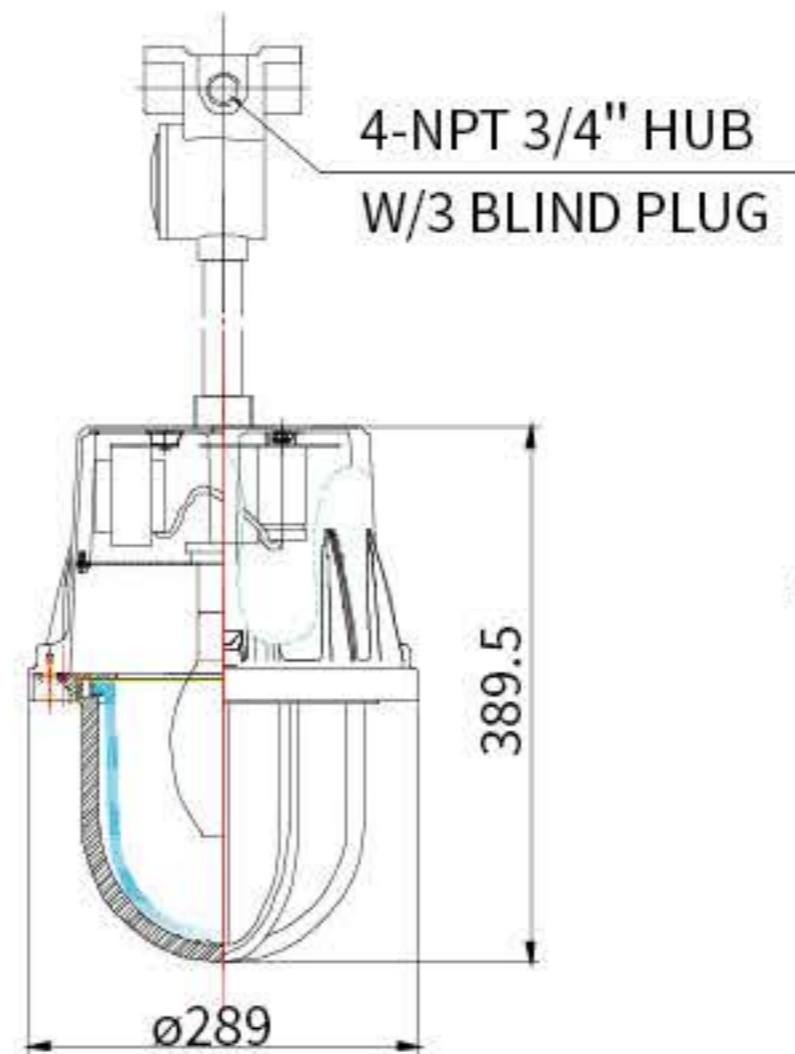

Celling Type

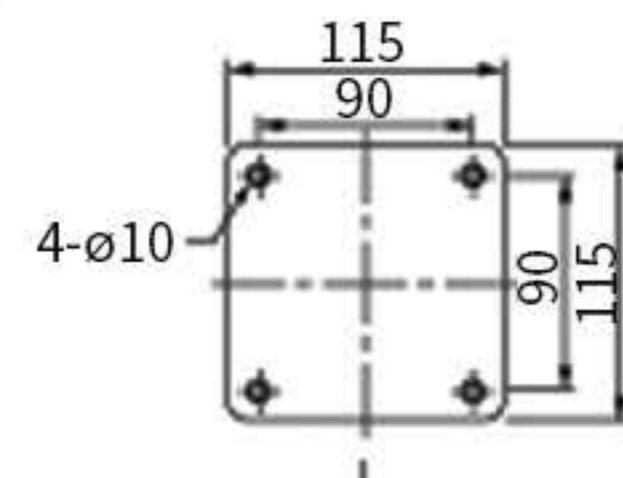
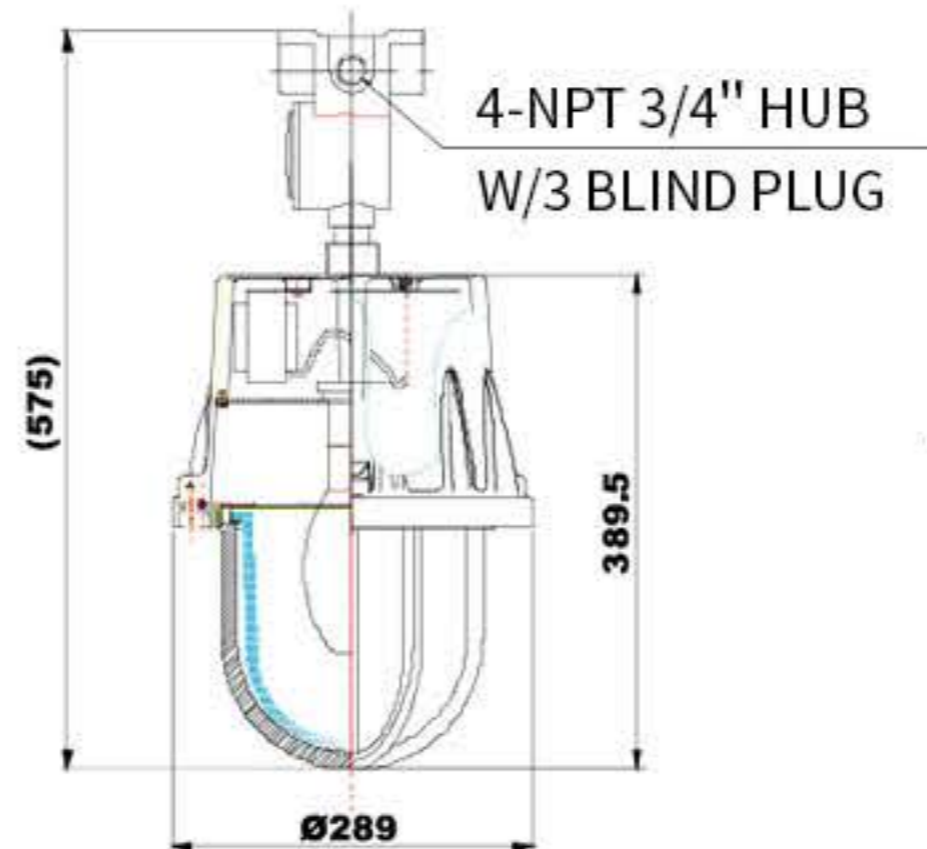

Bracket Type

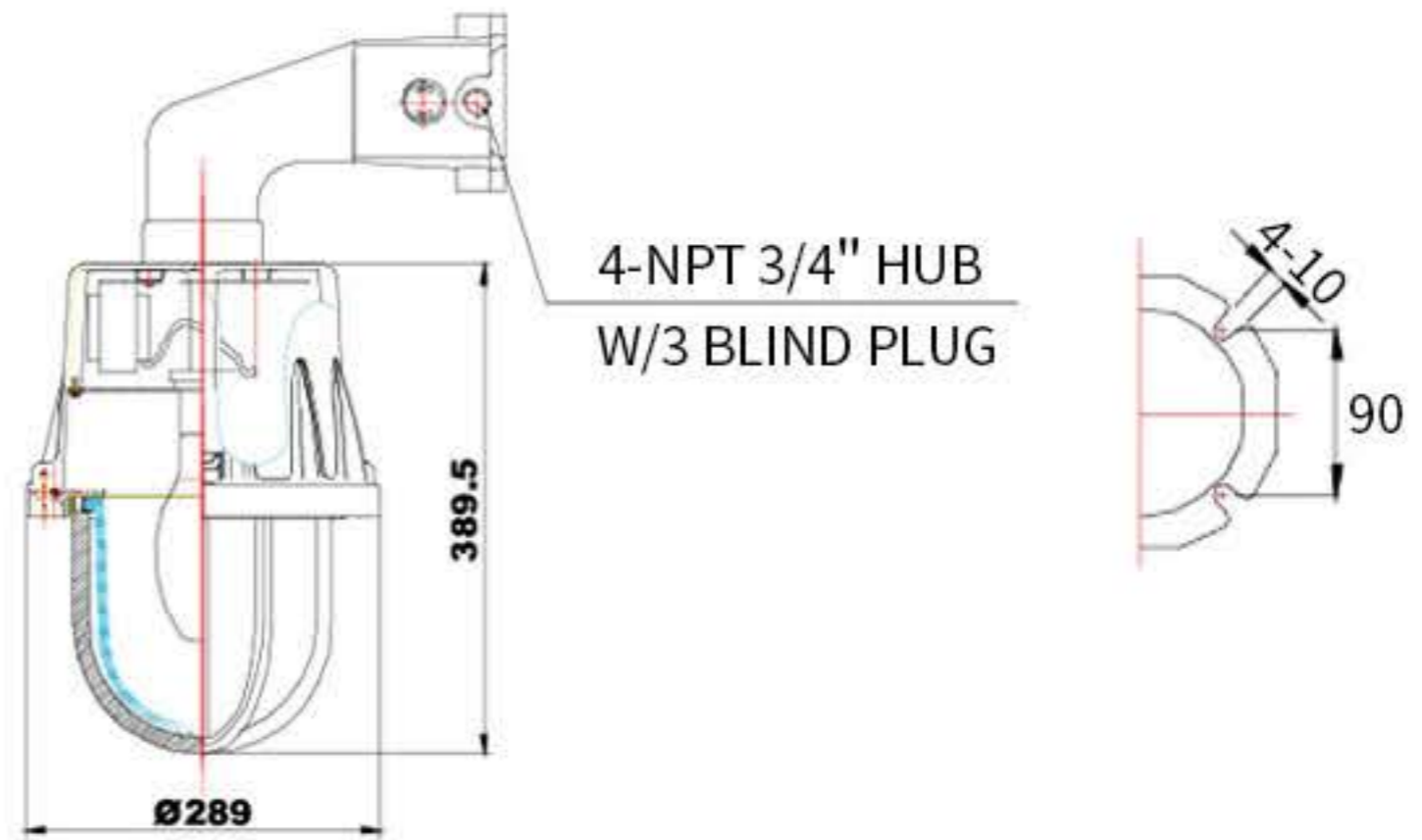

Pole Type

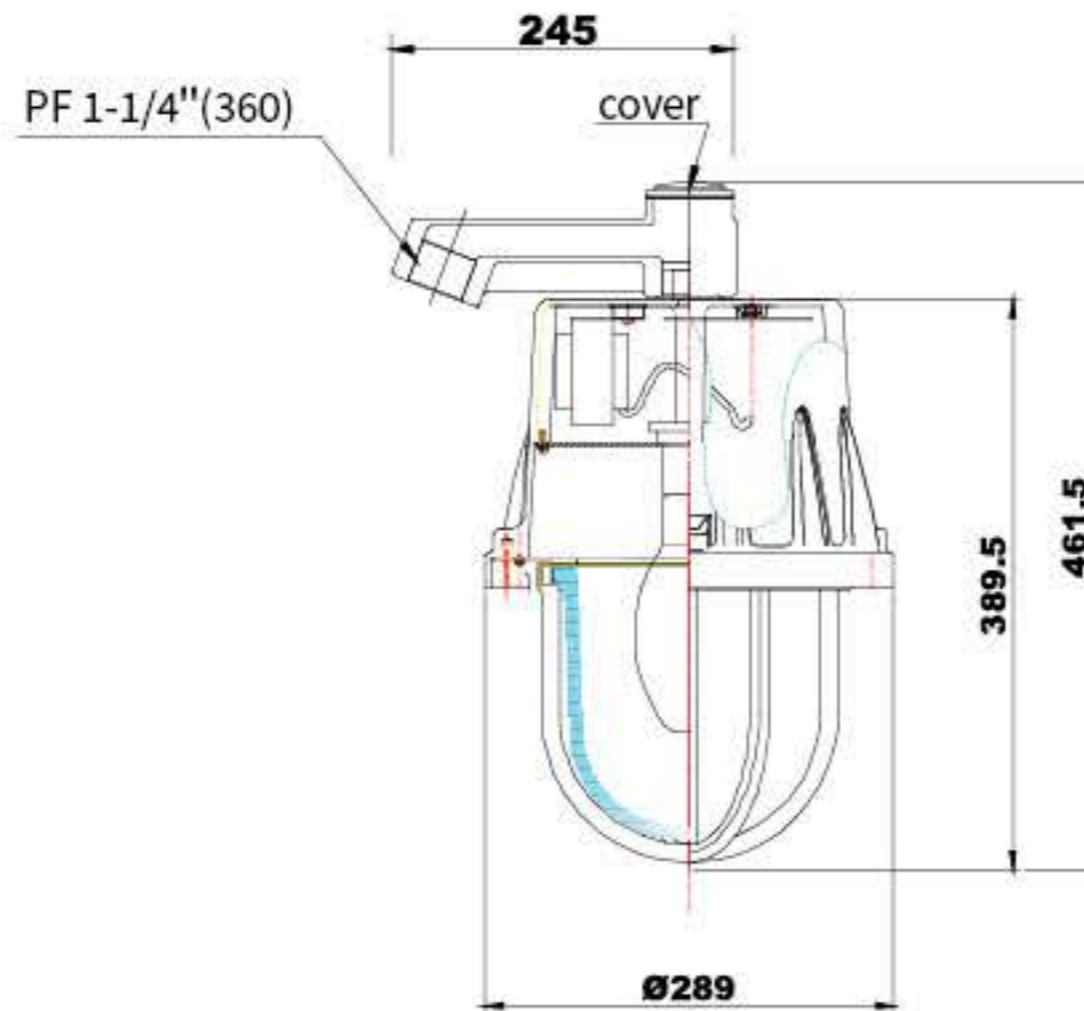

제품 사양

Specification

* 분진 · 방폭 등급 : Ex tD A21 T200°C IP66* / AC 220V 50/60Hz			
Type	Model Number	Lamp Watt(W)	Weight(kg)
Pendant (긴타입)	SPVL-TD-170	70	10.5
Celling (천정형)	SPVL-TD-270	70	10
Bracket	SPVL-TD-370	70	12
Pole	SPVL-TD-470	70	

<재 질>

Mounting Box, Body, Hood : Die Cast Aluminum Alloy /
 Globe Guard : Die Casting Ballast Housing : Steel & Die Cast Aluminum Alloy /
 Globe : Heat Resistant Hard Glass
 Inner Reflrctor : High Purity Sheet Aluminum /
 Mogul : Porcelain With Mogul Socket /
 Pole : Steel

- ▶ 폭발 위험 물질 계량 및 PSM(Process Safety Management) / 화관법 / 화평법 적용 대상 업체에 사용
- ▶ 석유화학, 화학계열, 도료, 잉크, 가스, LPG 등 폭발 위험성이 있는 제품 업체에 사용