



Since 1994, DIGITAL LEADER Axis Sensitive Co. Ltd



Industrial Explosion Proof Balance Scales

MODEL : WFLL-80W



www.axis123.com



제품 규격 [UNIT : mm]

Product Specification

Pendant Type

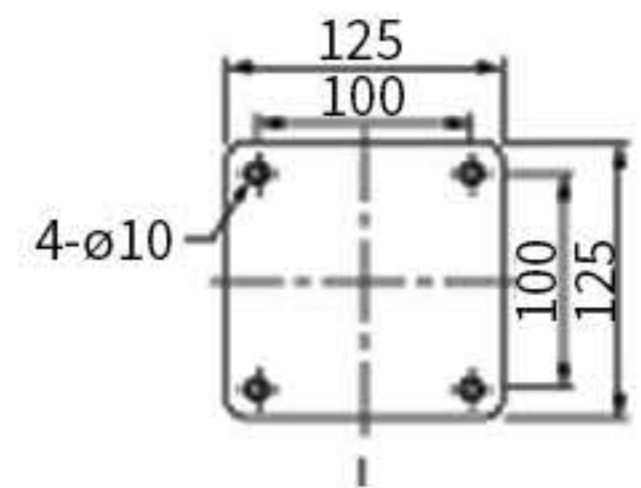
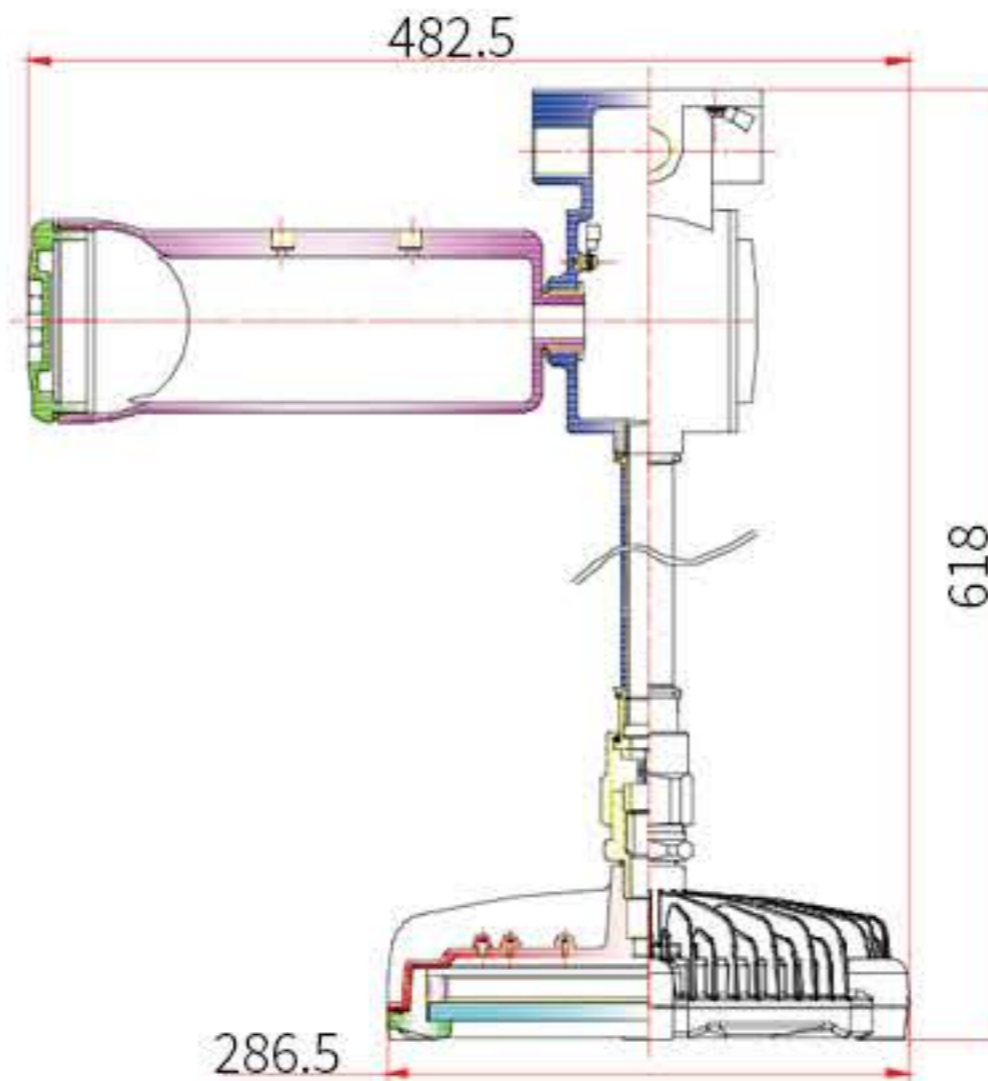

Celling Type

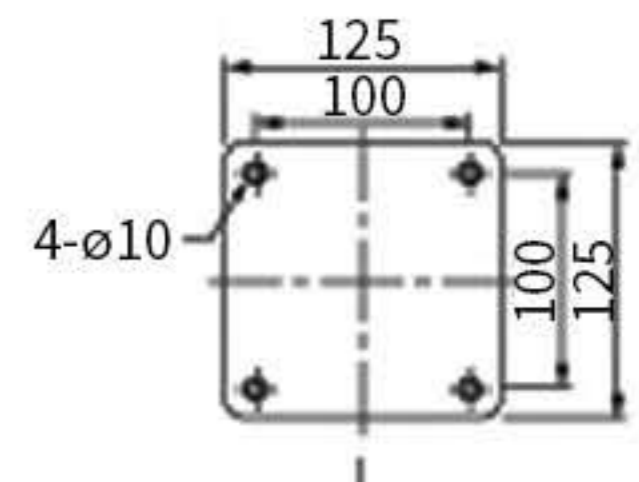
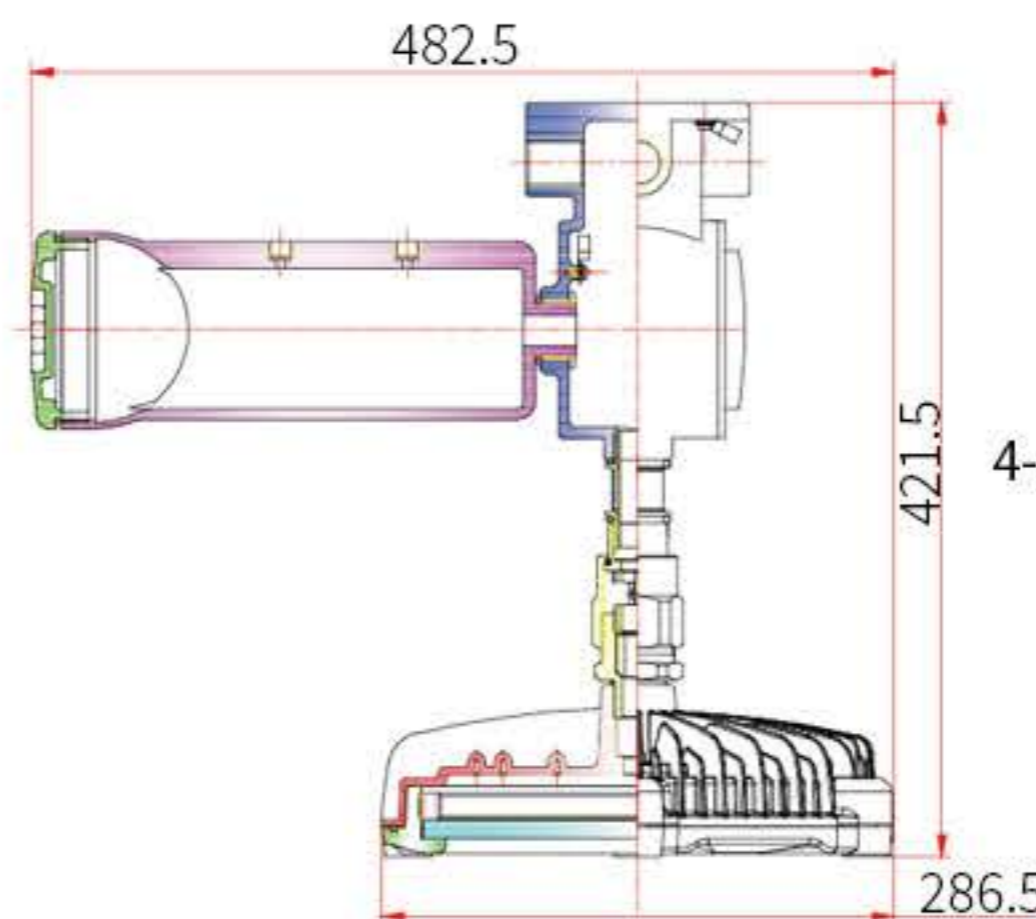

90° Bracket Type

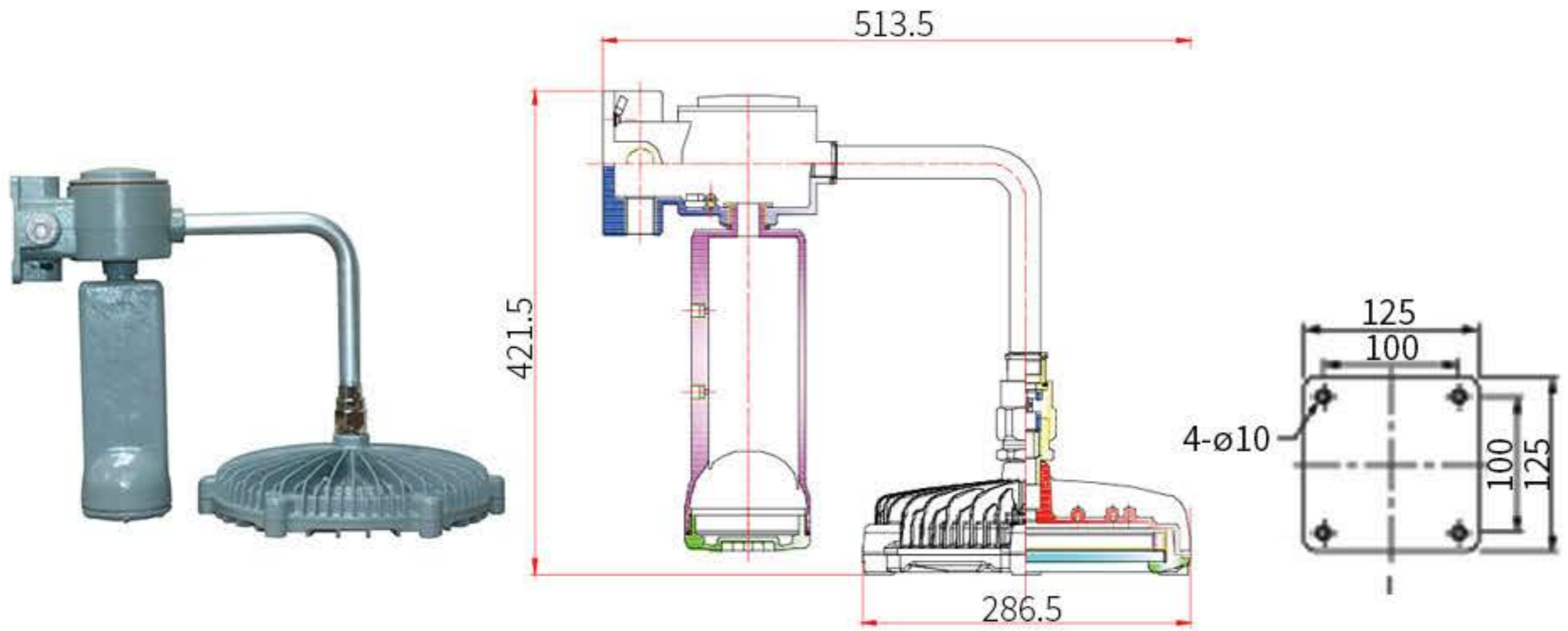

40° Bracket Type

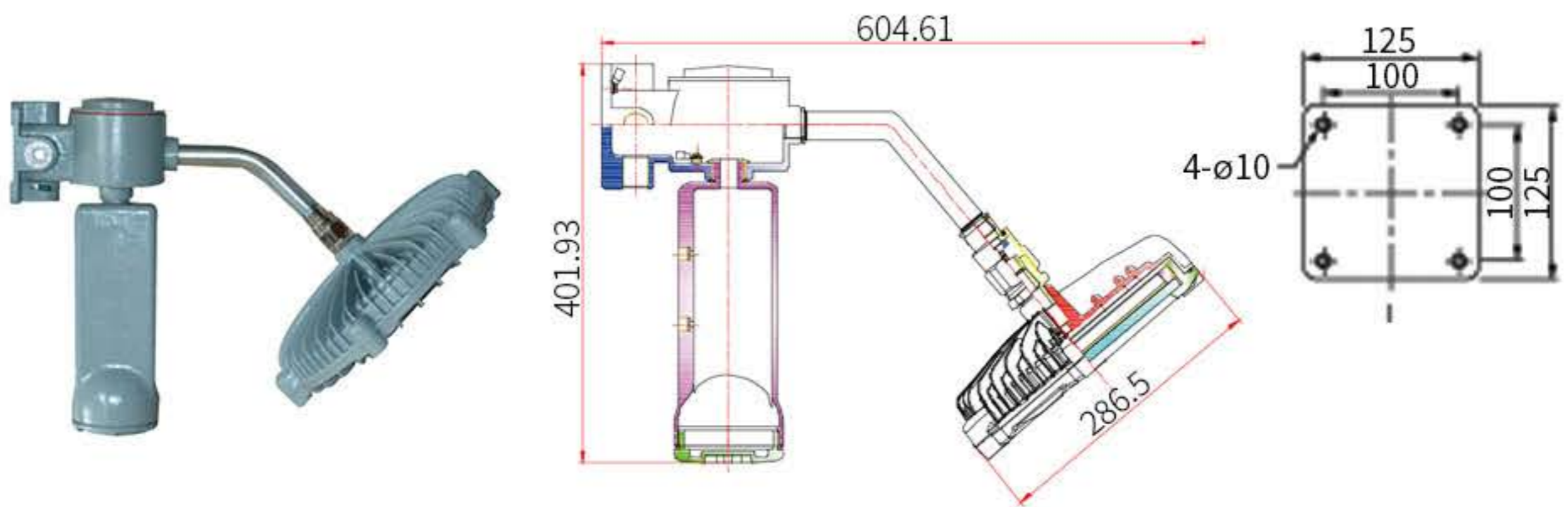

제품 사양

Specification

* 방폭·방수/분진 등급 : Ex d IIC T6 IP65 / Ex tD A21 T85°C IP65*			
Type	Model Number	Lamp Watt(W)	Weight(kg)
Pendant (긴타입)	WFLL-D-180D	80	11
Ceiling (천정형)	WFLL-D-280D	80	10.5
90°Bracket	WFLL-D-380D	80	11
40°Bracket	WFLL-D-480D	80	11
Pole	WFLL-D-580D	80	
전 원	AC 220V 50/60Hz		

<재 질>

Mounting Box, Body : Die Cast Aluminum Alloy /
 Converter Body : Cast Aluminum Alloy /
 Glass : Heat Resistant Hard Glass /
 Glass Guard : STS304

- ▶ 폭발 위험 물질 계량 및 PSM(Process Safety Management) / 화관법 / 화평법 적용 대상 업체에 사용
- ▶ 석유화학, 화학계열, 도료, 잉크, 가스, LPG 등 폭발 위험성이 있는 제품 업체에 사용