



Since 1994, DIGITAL LEADER Axis Sensitive Co. Ltd



# Industrial Explosion Proof Balance Scales

MODEL : FFL-LED-32W



제품 규격 [UNIT : mm]

Product Specification



Pendant (긴타입)

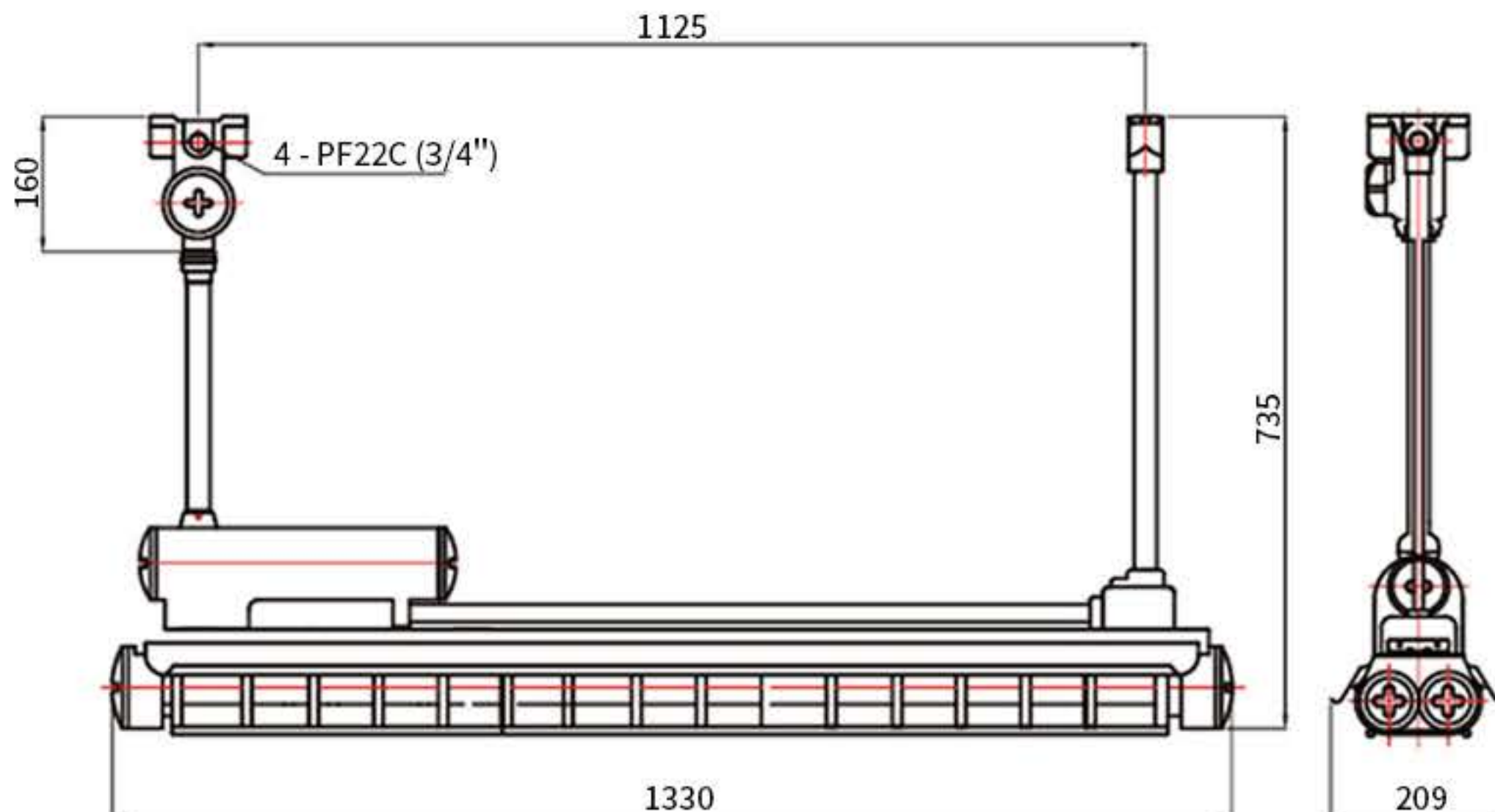
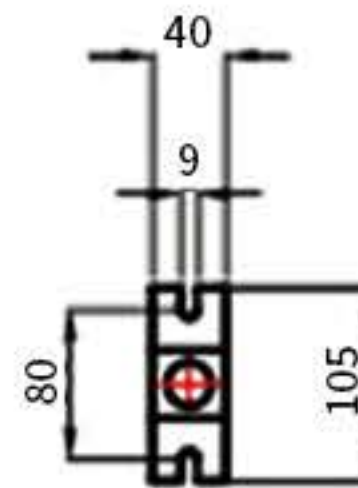
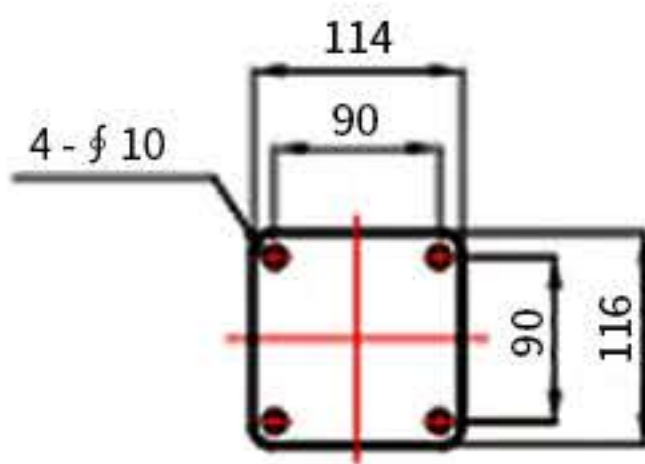





Celling (천정형)

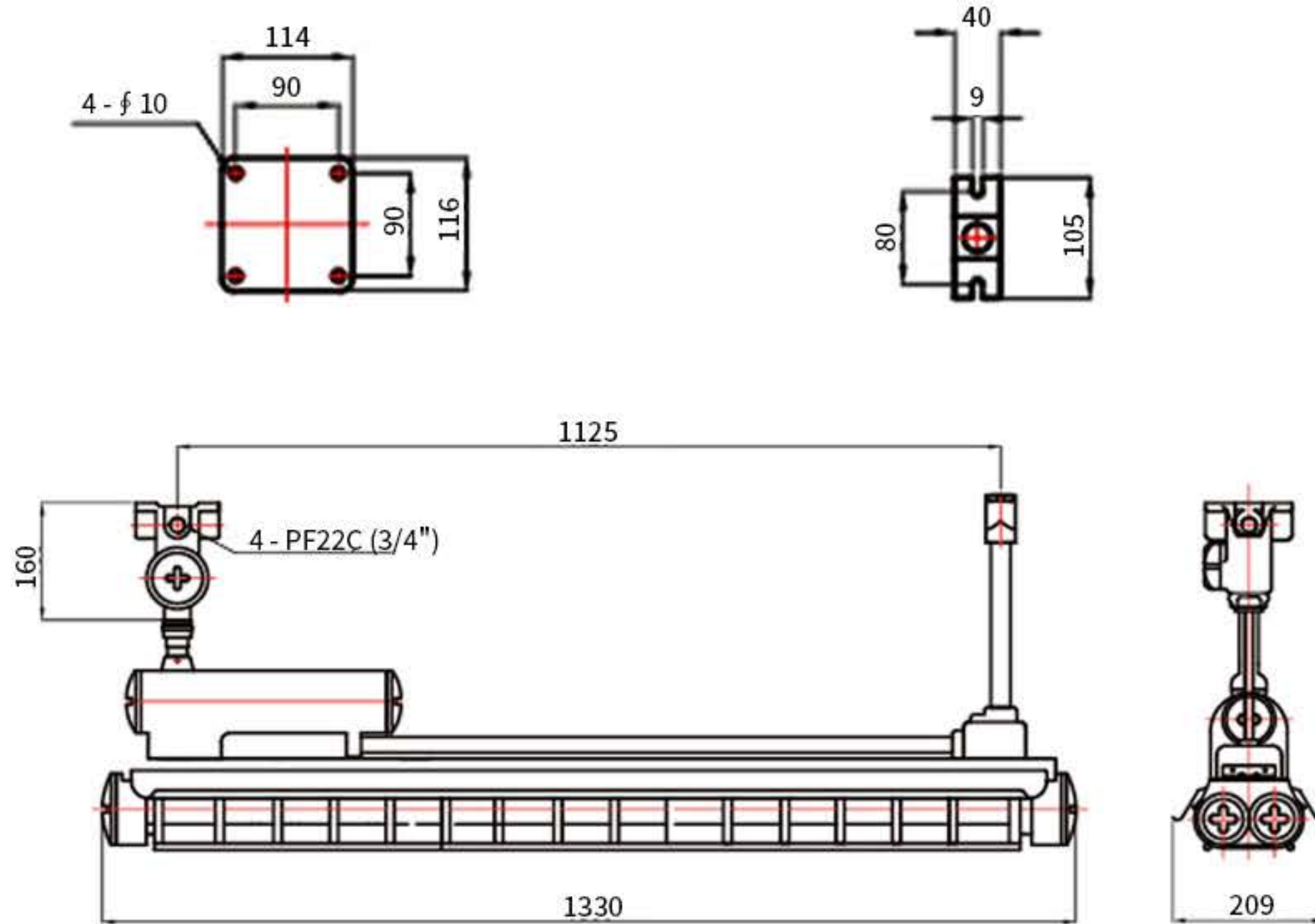

제품 사양

Specification

* 방폭 · 방수 등급 : Ex d IIC T6 IP65* / AC 220V 50/60Hz			
Type	Model Number	Lamp Watt(W)	Weight(kg)
Pendant (긴타입)	FFL-3211	32 X 1	
	FFL-3212	32 X 2	16.6
Celling (천정형)	FFL-3221	32 X 1	
	FFL-3222	32 X 2	16.6
전 원	AC 22V / 50/60Hz		

- ✓ 재질 : Mounting Box, Body : Die Cast Aluminum Alloy
- ✓ Vallast Housing : Cast Aluminum Alloy / Reflector : cold Rolled Sheet Steel / Tube Glass : Heat Resistant hard Glass / Guard : Steel / Pole : Steel

- ▶ 폭발 위험 물질 계량 및 PSM(Process Safety Management) / 화관법 / 화평법 적용 대상 업체에 사용
- ▶ 석유화학, 화학계열, 도료, 잉크, 가스, LPG 등 폭발 위험성이 있는 제품 업체에 사용