

안전증방폭형 엘보 & 티

Class, Division 1, Ex e II



LL Types

Catalogue	Conduit Size	Dimensions(mm)			Weight(kg)
		A	B	C	
LL 16	16 (1/2")	60	46	125	0.6
LL 22	22 (3/4")	67	53	134	0.8
LL 28	28 (1")	86	63	161	1.02
LL 36	36 (1 1/4")	95	73	171	1.5
LL 42	42 (1 1/2")	100	83	190	2.2
LL 54	54 (2")	110	100	216	3.2
LL 70	70 (2 1/2")	130	117	249	5
LL 82	82 (3")	142	129	276	6
LL 104	104 (4")	170	156	305	9

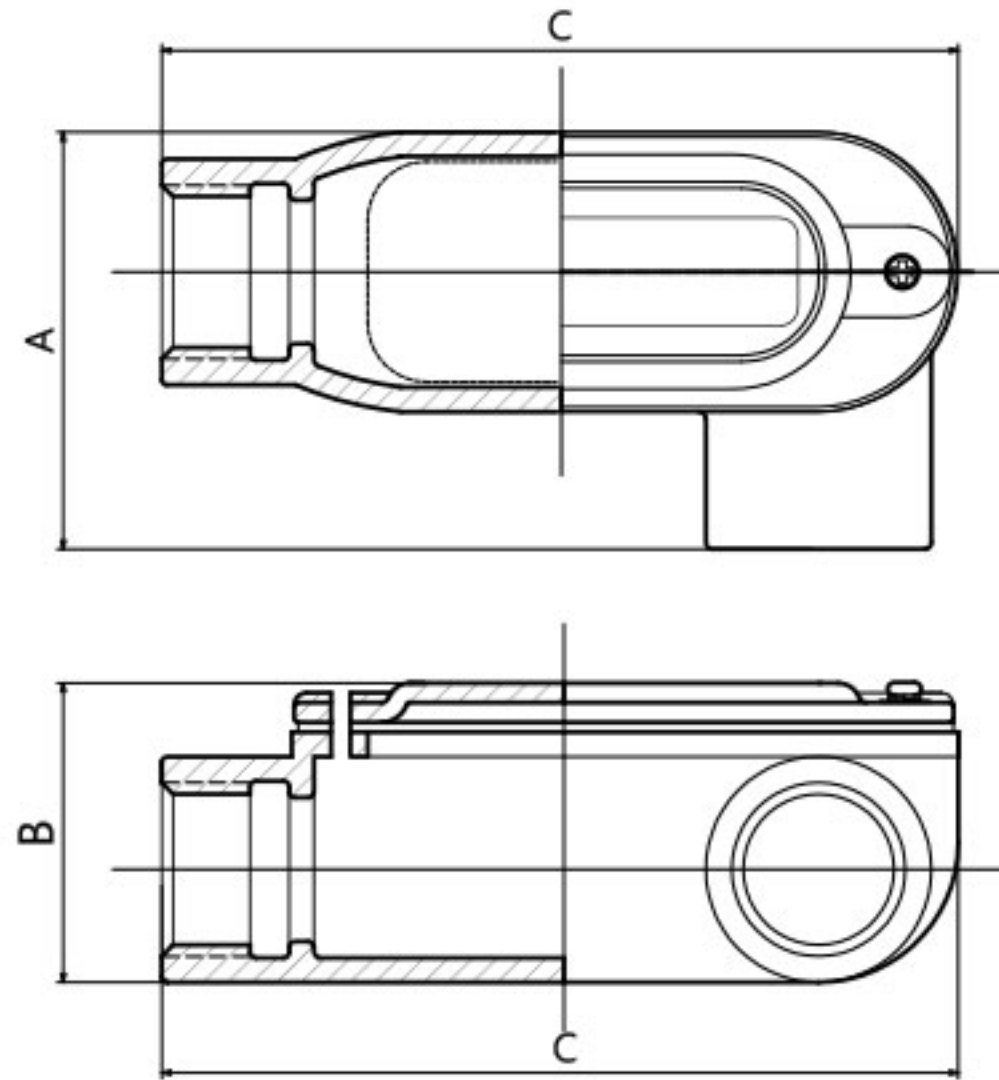

LR Types

Catalogue	Conduit Size	Dimensions(mm)			Weight(kg)
		A	B	C	
LR 16	16 (1/2")	60	46	125	0.6
LR 22	22 (3/4")	67	53	134	0.8
LR 28	28 (1")	86	63	161	1.02
LR 36	36 (1 1/4")	95	73	171	1.5
LR 42	42 (1 1/2")	100	83	190	2.2
LR 54	54 (2")	110	100	216	3.2
LR 70	70 (2 1/2")	130	117	249	5
LR 82	82 (3")	142	129	276	6
LR 104	104 (4")	170	156	305	9

