



Since 1994, DIGITAL LEADER Axis Sensitive Co. Ltd



# Industrial Explosion Proof Air Hoist

MODEL : H2-200SPB



[www.axis123.com](http://www.axis123.com)



제품 규격 [UNIT : mm]

Product Specification

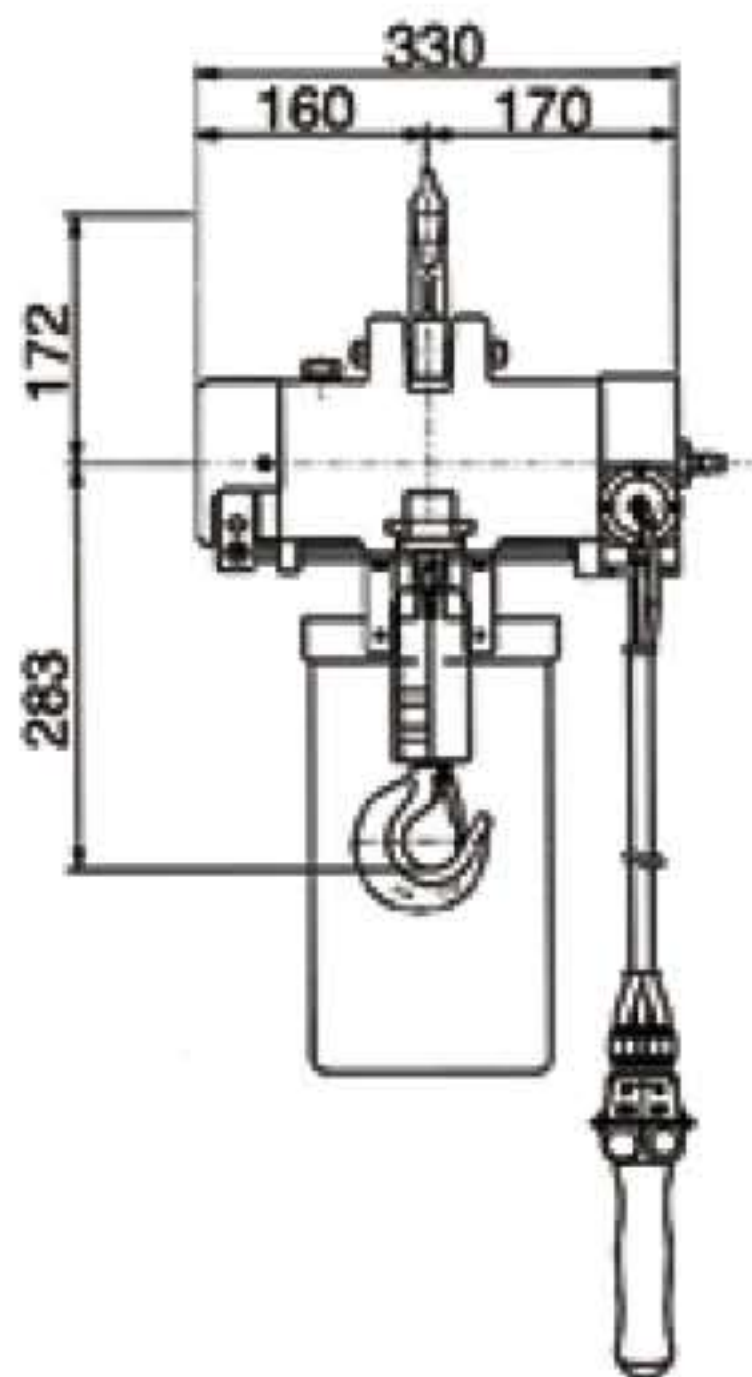



- ▶ H2-100SPB는 상·하 운반용 호이스트
- ▶ PSM 대상 지역 및 인화성, 휘발성, 습기, 분진, 고온 지역 사용
- ▶ 다양한 용량 (250 / 500 / 1,000 / 2,000 kg)의 모델
- ▶ 상·하 이동시 체인의 오버로드 기능과 속도 제어 가능

Model	Type	Capacity (kg)	Chain Falls	Speed (m/min)	
				Up	Down
H2-200SPB	Standard	2000	2	3.2	4

Lift (m)	Air Pressure (kg/cm <sup>2</sup> )	Air Consumption (m <sup>3</sup> /min)	Air Inlet	Mass (kg)
3	6	1.6	1/2"	45

